

COCKPIT ENGINE INSTRUMENTATION



H9000 Series AUTOTEMP[®] / AUTOTAK[®] Indicators

The H9000 Series Indicators are solid-state analog/digital gauges that measure the output of ANSI type K thermocouples or frequency from a tachometer generator or magnetic pick-up.

Because temperature and speed are two of the most critical engine parameters used in monitoring mechanical integrity, prolonged engine life is dependent upon avoiding operation at these limits. Howell's H9000 Series Indicators accurately provide these imperative measurements. The H9000 Series Indicators supply is ± 1 °C, ± 0.1 %RPM, pointer accuracy is ± 6 °C, ± 0.6 %RPM of digital display.

H9000 Series single purpose indicators have both analog pointers and digital displays for redundancy. Maximum response time is one and one-half seconds to stabilize within ± 1 °C, ± 0.1 %RPM at full-scale.



¹ AUTOTEMP[®] and AUTOTAK[®] are registered trademarks of Howell Instruments, Inc.

Howell Instruments, Inc.
8945 South Freeway
Fort Worth, Texas 76140
www.howellinst.com
817-336-7411
Fax: 817-336-7874
info@howellinst.com

COCKPIT ENGINE INSTRUMENTATION

H9000 Series AUTOTEMP®/AUTOTAK® Indicators

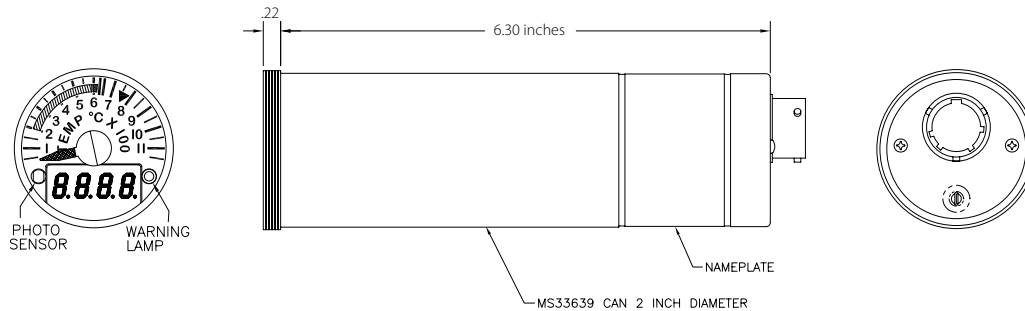

Specifications

Power Input	28 VDC nominal, 18 to 32 VDC, 115 VAC, $\pm 10\%$, 380 to 420 Hz units require 10W maximum.
Signal Input	Temperature – ANSI Type K Thermocouple. Range 0 to 1200 °C (0 to 2000 °F). Frequency – 3.5 Hz to 20 KHz, 500 mV to 50 Vrms tachometer generator. Range 5.0 to 120.0 %RPM.
Digital Display	Four, seven segment with decimal point, green LED characters, NVG compatible per MIL-L-85762A. Brightness automatically controlled via an integral photoelectric cell.
Case	Per MS33639, 2 inch diameter, 6.5 inches long, hermetically sealed. (3 inch diameter available)
Weight	1.5 lbs Maximum
Connector Interface	MIL-C-26482 and MIL-C-5052
Environmental	DO-160C
Optional Integral Lighting	5V AC/DC or 28 VDC system. White, red, blue/white, or NVG.
Optional Warning Lamp	An integral warning lamp can be supplied in red, yellow, orange and NVG blue/green. Limits set to customer specifications.
Certification	TSO C43c, C49b

Other application examples:

Oil Temperature

Oil Pressure

Torque

Fuel Flow

Oil Quantity

Engine Pressure Ratio (EPR)

Fuel Quantity



Howell Instruments, Inc. • 8945 South Freeway • Fort Worth, Texas 76140
www.howellinst.com • 817-336-7411 • Fax: 817-336-7874 • info@howellinst.com